

# DISPLAY D90

24 m  
IP41



## DISPLAY D90

Beauty is debatable. But in the case of the Display D90 we are agreed. The brushed stainless steel enclosure is a highlight, in the hotel foyer, in the executive suite and any other building with high standards.



DISPLAY D90 SYSTEM LUMINAIRE RECHARGEABLE BATTERY LUMINAIRE

Viewing distance	24 m	
Degree of protection	IP41	
Class	I	
Enclosure material	Stainless steel	
Enclosure colour/surface	brushed	
Terminal block	3 x 2.5 <sup>2</sup> for through wiring	
Light source	LED	
Ambient temperature	-20° C to +40° C	0° C to +40° C
Connected load (AC/DC)	10.1 VA/6.0 W	
Supply voltage	230V ± 10 %, 50/60 Hz / 176-275 V DC	230V ± 10 %, 50/60 Hz
Rechargeable battery	4.8 V/0.8 Ah (NiMH) W/C/R 3.6 V/2.5 Ah (NiCd) wire, recessed box	

VERSIONS

1 h with auto-check   with BUS check		•   •
3 h with auto-check   with BUS check		•   •
8 h with auto-check   with BUS check		
without monitoring module	•	
with monitoring module	•	
with DALI monitoring	•	
Cinema version	•	
Luminous flux in normal mode 10 %		

SPECIAL FEATURE

- Power supply via wire suspension

OPTIONS /ACCESSORIES

- Wire lengths up to 6 m
- Concrete adapter for surface-mounted installation
- Concrete casting box (DG6\_BET)

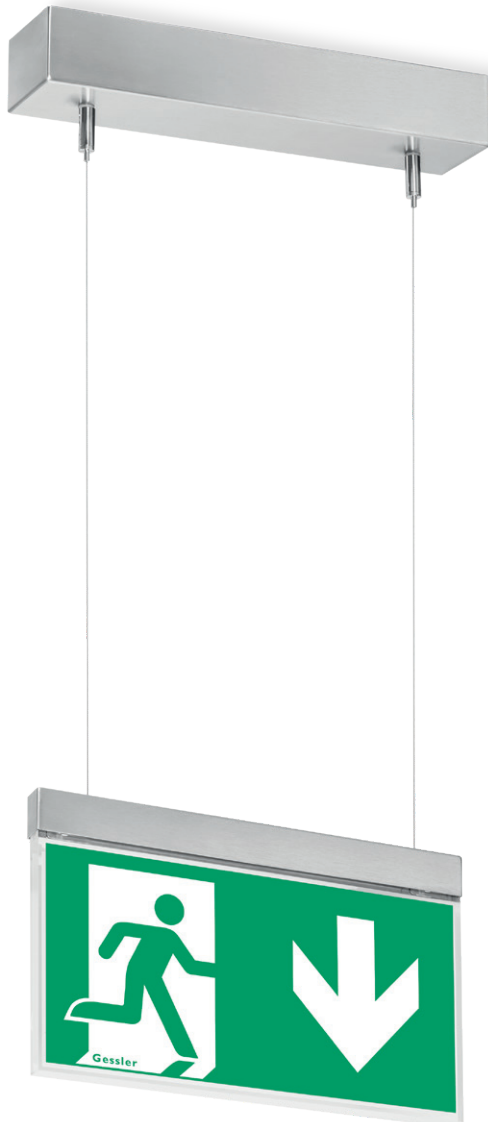

D90W WALL MOUNTED

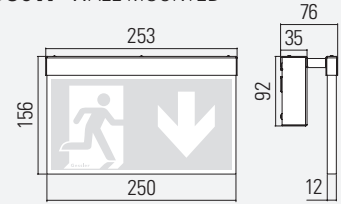

D90D CEILING MOUNTED

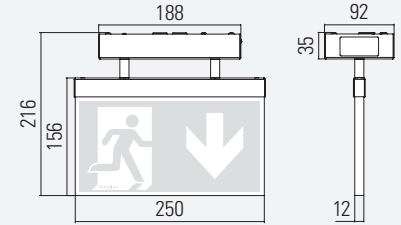

D90P PENDANT

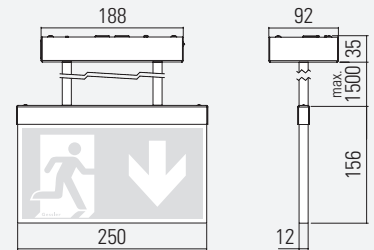

D90F SUSPENDED, RECESSED BASE

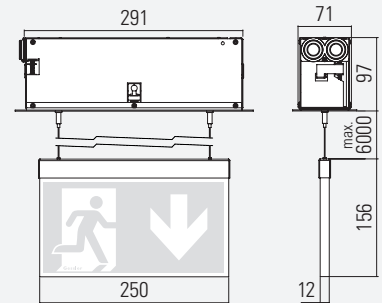

Ceiling cutout: 295 mm x 75 mm  
Maximum ceiling thickness: 43 mm

D90S SUSPENDED

