

DISPLAY D91 31 m IP41



DISPLAY D91

The apple doesn't fall far from the tree. The large brother of the Display D90 also has a stylish presence in an equally elegant stainless steel enclosure. The Display D91 is available for 5 types of installation and also scores bonus points with its large viewing distance of 31 m.



DISPLAY D91 SYSTEM LUMINAIRE RECHARGEABLE BATTERY LUMINAIRE

Viewing distance	31 m	
Degree of protection	IP41	
Class	I	
Enclosure material	Stainless steel	
Enclosure colour/surface	brushed	
Terminal block	3 x 2.5 [□] for through wiring	
Light source	LED	
Ambient temperature	-20° C to +40° C	0° C to +40° C
Connected load (AC/DC)	10.1 VA/6.0 W	
Supply voltage	230V ± 10 %, 50/60Hz/176-275 V DC	230V ± 10 %, 50/60 Hz
Rechargeable battery	4.8V/0.8 Ah (NiMH)	

VERSIONS

1 h with auto-check with BUS check	• •
3 h with auto-check with BUS check	• •
8 h with auto-check with BUS check	
without monitoring module	•
with monitoring module	•
with DALI monitoring	•
Cinema version	•
Luminous flux in normal mode 10 %	

SPECIAL FEATURE

- Power supply via wire suspension

OPTIONS /ACCESSORIES

- Concrete adapter
- Concrete casting box



D91W WALL MOUNTED

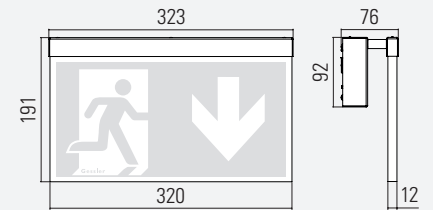

D91D CEILING MOUNTED

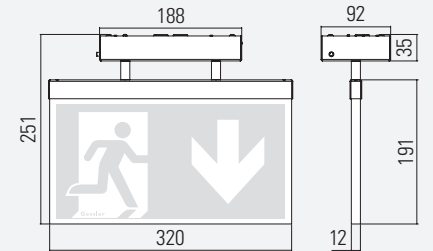

D91P PENDANT

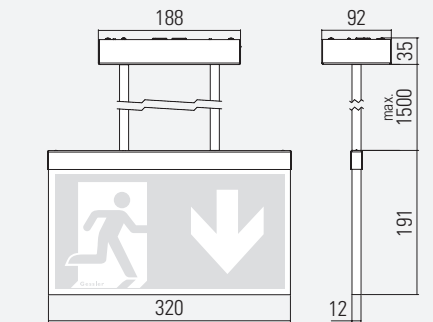

D91F SUSPENDED, RECESSED BASE

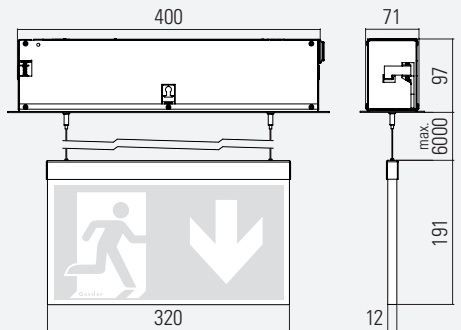

Ceiling cutout: 405 mm x 75 mm
Maximum ceiling thickness: 43 mm

D91S SUSPENDED

